



## **XESHES 13.5kWh Energy Storage Battery**

### **User Manual**

Model: XESHES -U-48V13.5kWh-A | XESHES-U-48V13.5kWh-A-H

**V1.5 2025.11.05**

Notice: Please read this user manual carefully and follow the instructions before installation of this battery.

# Table of Contents

|  |           |
|--|-----------|
| <b>Introduction.....</b>   | <b>1</b>  |
| What Is the XESHES 13.5kWh Energy Storage Battery .....          | 1         |
| System Operation Modes .....                                     | 1         |
| Purpose of This Manual.....                                      | 2         |
| <b>Chapter 1. Product Introduction.....</b>                      | <b>3</b>  |
| 1.1 Symbols Used .....   | 4         |
| <b>Chapter 2. Precautions .....</b>                              | <b>6</b>  |
| <b>Chapter 3. Step-by-Step Checklist .....</b>                   | <b>9</b>  |
| 3.1 Step 1 — Inspect the Parts List.....                         | 9         |
| 3.2 Step 2 — Read the User Manual .....                          | 10        |
| 3.3 Step 3 — Verify Installation Tools.....                      | 11        |
| 3.4 Step 4 — Site Risk Assessment / Planning Approval .....      | 12        |
| 3.5 Step 5 — Wall & Structural Requirements .....                | 12        |
| 3.6 Step 6 — Select Installation Location.....                   | 13        |
| 3.7 Step 7 — Plan Installation Spacing .....                     | 15        |
| <b>Chapter 4. Installation.....</b>                              | <b>15</b> |
| 4.1 Junction Box System Installation (Optional).....             | 16        |
| 4.2 Rear Bracket Installation.....                               | 18        |
| 4.3 Product Installation .....                                   | 19        |
| <b>Chapter 5. Wiring.....</b>                                    | <b>20</b> |
| 5.1 Wiring Diagram .....   | 21        |
| 5.2 Wiring Details.....  | 22        |
| <b>Chapter 6. Commissioning, Operation and Maintenance .....</b> | <b>24</b> |
| 6.1 Commissioning Steps.....                                     | 24        |
| 6.2 Operation.....   | 24        |
| 6.3 Cleaning .....   | 26        |
| 6.4 Maintenance .....  | 26        |
| <b>Chapter 7. Appendix .....</b>                                 | <b>27</b> |
| 7.1 Troubleshooting .....  | 27        |
| 7.2 Emergency Handling.....                                      | 27        |
| 7.3 Specification Datasheet.....                                 | 29        |
| 7.4 Product Warranty .....                                       | 30        |

# Introduction

## What Is The XESHES 13.5kWh Energy Storage Battery?

The XESHES 13.5kWh Energy Storage Battery utilizes high-performance Lithium Iron Phosphate (LiFePO<sub>4</sub>) cells, designed to improve the efficiency of photovoltaic (PV) systems, reduce electricity costs, and lower carbon emissions.

It features a safe, durable, and aesthetically refined design with comprehensive electrical protection and a service life exceeding 10 years.

The integrated Battery Management System (BMS) allows up to 7 units of the same model to be connected in parallel, enabling flexible expansion of the total system storage capacity based on user needs.

## System Operation Modes

### 1. Self-Consumption Mode (Load > Battery > Grid)

This mode prioritizes the use of locally generated solar energy. It is ideal for locations where grid electricity costs are high or where maximizing solar utilization is desired.

### 2. Peak Shaving Mode: Load > Battery > Grid (when discharging)

Used in areas with time-of-use (TOU) or peak/valley electricity pricing. The battery can be charged using solar energy or off-peak grid electricity and discharged during peak tariff periods to reduce energy costs.

### 3. Standby Mode: (Battery > load > grid)

Recommended for regions with frequent power outages. In this mode, the system maintains a reserved level of stored energy so that essential loads can continue operating when the grid is disconnected.

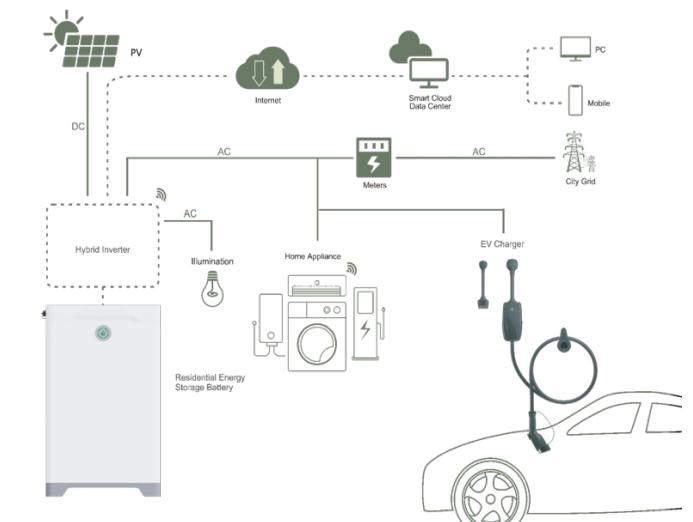

Operating Diagram of Residential Energy Storage System

## Purpose of This Manual

The purpose of this user manual is to provide essential information for users and detailed guidance for installers to ensure that the XESHES Energy Storage Battery is installed, operated, and maintained correctly and efficiently. This manual outlines the key standards, engineering requirements, and installation practices necessary to achieve optimal system performance and safety.

This manual applies to the following models of the XESHES energy storage system:

- **XESHES-U-48V13.5kWh-A**
- **XESHES-U-48V13.5kWh-A-H** (with integrated heating film)

These products must be installed by qualified professionals who have completed certified energy storage installation training. For future product generations, Pion Power will continue working closely with distributors to expand and enhance installer training programs.

All specifications and instructions in this manual are subject to the latest version. As part of Pion Power's commitment to continuous improvement, we reserve the right to modify product design and documentation without prior notice.

Images and illustrations in this manual are for reference only. Actual product details may vary depending on model version and regional availability. For more information on installation training and obtaining installer certification, please visit:

**<https://www.pionpowertech.com/>**

Thank you for choosing the Pion Power XESHES Energy Storage Battery. With proper installation and maintenance, we are confident that the system will provide you with reliable, long-term clean energy performance.

### Important Notes

This manual does not cover all safety precautions required for working with electrical energy storage systems. All installations must comply with applicable Health and Safety Regulations, electrical codes, and relevant national or regional standards.

This manual provides installation guidance but does not guarantee workmanship. Installers are responsible for performing all tasks with professionalism, accuracy, and care.

- All electrical work must be carried out by a licensed electrician.
- Installers must verify that the XESHES battery is appropriate for the intended application and that the paired PCS (Power Conversion System) is certified by Pion Power to ensure optimal compatibility and performance.



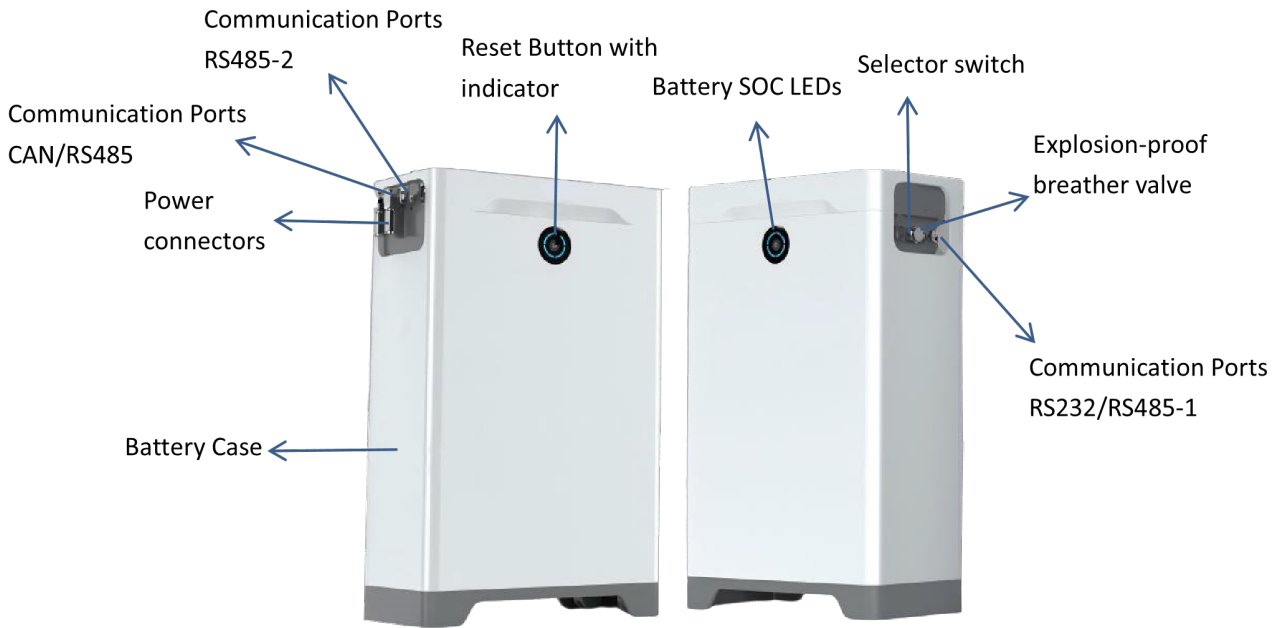



# Chapter 1. Product Introduction













Residential energy storage battery



| Item                           | Description   |
|--------------------------------|---|
| Selector switch                | Turn ON & Turn OFF Switch for the battery                         |
| Power Connectors               | Used on the +/- terminal of the battery                           |
| Communication Ports            | Used for PCS communication, parallel connection and commissioning |
| Reset Button with indicator    | Used to realize activation, sleep and reset of the battery system |
| Battery Case                   | Used for natural cooling  |
| Battery SOC LEDs               | Used to display battery SOC (State of Charge)                     |
| Explosion-proof breather valve | Explosion-proof valve used to release pressure in the battery     |



## 1.1 Symbols Used

| Symbol  | Description   |
|---|---|
|    | <b>Warning!</b><br>Indicates a potentially hazardous situation which, if not avoided, may result in <i>minor injury</i> . |
|    | <b>Attention!</b><br>Indicates a condition that may cause <i>property damage</i> if instructions are ignored.             |
|    | <b>Information</b><br>Provides useful tips for optimal installation, operation, and maintenance.                          |
|   | The device may become hot during operation. Do not touch the surface.   |
|  | Follow all guidelines in the relevant instruction manuals.  |
|  | Refer to the installation manual for proper disposal and recycling procedures.  |

| No. | Symbol  | Description                      |
|-----|---|----------------------------------|
| 1   |  | DC                               |
| 2   |  | AC                               |
| 3   |  | DC and AC                        |
| 4   | <b>3~</b>   | Three-phase AC                   |
| 5   | <b>3N~</b>  | Three-phase AC with neutral line |

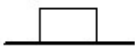
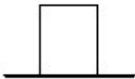
|    |  |   |
|----|--|---|
| 6  |   | Ground terminal   |
| 7  |   | Protective ground terminal                                      |
| 8  |   | Housing ground terminal   |
| 9  |   | Refer to the operation instructions                             |
| 10 |   | Power on  |
| 11 |   | Power off   |
| 12 |  | Double insulation or reinforced insulation protection equipment |

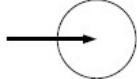
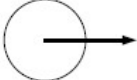
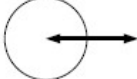
| No. | Symbol  | Description             |
|-----|---|-------------------------|
| 13  |  | Caution! Electric shock |
| 14  |  | Caution! Hot surface    |
| 15  |  | Danger!                 |
| 16  |  | Button pressed          |
| 17  |  | Button released normal  |

|    |   |   |
|----|---|---|
| 18 |  | Input terminal                                      |
| 19 |  | Output terminal                                     |
| 20 |  | Two-way terminal                                    |
| 21 |  | Electric shock! Battery discharges at set intervals |
| 22 |  | Attention,<br>Wear hearing protection equipment     |

## Chapter 2. Precautions

### Warning

Failure to follow the precautions in this section may result in serious personal injury, electrical hazards, fire, explosion, or property damage.

Please observe the following safety requirements at all times:

#### 1. Explosion Hazard

- Avoid any strong impact, drop, or collision with the product.
- Do not crush, squeeze, or puncture the battery enclosure.
- Do not handle or move the product during a fire or immediately after a thermal event.
- If the battery emits smoke, odor, or unusual noise, evacuate the area immediately and contact authorized service personnel.

## 2. Fire Hazard

- Do not expose the product to high temperatures (above 50°C).
- Keep the product away from open flames, fireplaces, heaters, or other heat sources.
- Avoid installation or storage under direct sunlight.
- Ensure that the battery connectors do **not** come into contact with metal or conductive objects such as wires, tools, or jewelry.

## 3. Electric Shock Hazard

- Do not disassemble, open, or modify the battery without authorization.
- Never touch the product with wet hands or use it in wet environments.
- Do not expose the battery to rain, moisture, or any type of liquid.
- Keep children, pets, and unauthorized persons away from the product.

**Note:** High-voltage DC presents a significant risk. Only qualified electricians should perform electrical work.

## 4. Risk of Product Damage

- Prevent the product from coming into contact with liquids of any kind.
- Do not expose the system to abnormal or excessive voltage.
- Do not place heavy objects on top of the battery enclosure.
- Avoid bending, twisting, or applying force to the cables or connectors.
- When connecting the XESHES battery to the PCS, please wear the following personal protective equipment (PPE).



Insulating gloves



Safety goggles



Safety shoes

# Chapter 3. Step-by-step Checklist

This section provides an overview of the complete workflow for installing the XESHES Energy Storage Battery.

It covers all major steps - from pre-installation checks to mechanical installation, wiring, commissioning, and final verification.

The following checklist outlines the typical project sequence and serves as a quick reference for installers.

## Installation Steps

### Step 1- Inspect the Parts List

- Check the packaging for signs of damage.
- Verify all components and accessories against the parts list.

### Step 2- Read the User Manual

- Review all safety instructions and installation requirements.
- Ensure you understand wiring diagrams and configuration procedures.

### Step 3- Verify Installation Tools

- Confirm that all required tools, protective equipment, and materials are available and in good condition.

### Step 4- Conduct a Site Risk Assessment / Planning Approval

- Evaluate environmental and structural conditions.
- Ensure compliance with local electrical codes, building regulations, and AHJ requirements.

### Step 5- Review Wall and Structural Requirements

- Confirm the wall and ground can safely support the system.
- Ensure required fire-clearance and spacing are met.

### Step 6- Select an Appropriate Installation Location

- Choose a location that meets ventilation, safety, temperature, and accessibility requirements.
- Ensure the area is free from moisture, direct sunlight, and flammable materials.

### Step 7- Plan Installation Spacing









- Verify minimum clearance requirements on all sides.
- Confirm cable routing and access areas are unobstructed.

### 3.1 Step 1- Inspect the Parts List

Before beginning installation, carefully inspect all components included in the package.





Verify each item against the parts list below and confirm that all quantities are correct and undamaged.

Do not proceed with installation if any part is missing, damaged, or inconsistent with the list.

| Parts  | Diagram  |
|--|--|
| Energy Storage Battery                             |  ×1                        |
| Mounting Bracket                                   |  ×4                        |
| Mounting Bracket 2                                 |  ×1                      |
| Expansion Screws<br>(M8*70)                        |  ×4                      |
| User Manual  |  ×1                      |
| DC Cables<br>(#1/0 AWG)                            |  ×2 (installer-provided)  |
| AC Cables<br>(#10 AWG)                             |  ×2 (installer-provided)  |
| Network Cables<br>(Super Class 5 network<br>cable) |  ×2 (installer-provided) |

|                                   |  |
|-----------------------------------|--|
| <p>RJ45 Connectors<br/>(8P8C)</p> |  <p>×2 (installer-provided)</p> |
|-----------------------------------|--|

### Optional Components: Junction Box System

|  |  |
|--|--|
| <p>Junction Box Assembly</p>                             |  <p>×1</p>   |
| <p>Claw-Type Grounding Gasket (M4)</p>                   |  <p>×1</p>   |
| <p>Claw-Type Grounding Gasket (M5)</p>                   |  <p>×1</p>  |
| <p>Cross-Recessed Hexagon Truss Head Screws (M4×12 )</p> |  <p>×6</p> |
| <p>Cross-Recessed Hexagon Truss Head Screws (M4×16)</p>  |  <p>×3</p> |

## 3.2 Step 2- Read the User Manual

Before installing, connecting, operating, or maintaining the XESHES Energy Storage Battery, carefully read and fully understand all instructions in this manual.

Even when the battery appears to be disconnected, contact with its terminals can result in **burns, sparks, or potentially fatal electric shock** due to residual or stored energy.

The XESHES system must be installed **only by qualified and certified professionals**, including but not limited to:

- Licensed electricians
- Certified energy storage system installers
- Qualified contractors trained in high-voltage DC systems.

### 3.3 Step 3- Verify Installation Tools

Before beginning installation, ensure that all required tools are available, in good condition, and suitable for electrical and mechanical work.

| Tools                 | Diagram   | Description  |
|-----------------------|---|--|
| Hammer Drill (M14)    |    | Used for drilling mounting holes in the wall                               |
| Screwdriver           |    | Used to install or tighten mounting brackets                               |
| Insulating Tape       |    | Used for wire insulation and preventing electrical leakage                 |
| Torque Wrench         |    | Used to tighten expansion screws and ensure correct torque on terminals    |
| Multimeter            |  | Used to verify electrical continuity, voltage, and polarity                |
| Claw Hammer           |  | Assists with setting or securing expansion bolts                           |
| Transport Harness     |  | Required for safely lifting and moving the battery pack                    |
| Cable Crimping Pliers |  | Used to crimp Ethernet cables and install RJ45 connectors (T568B standard) |

## 3.4 Step 4- Conduct a Site Risk Assessment / Planning Approval

The XESHES Energy Storage Battery is designed to operate with a compatible PCS to store solar energy and supply power for residential, commercial, and light industrial applications.

Before installation, it is essential to assess the site to ensure safety, code compliance, and system performance.

Installation standards and regulatory requirements differ between countries and regions. Therefore, installers must verify that the project complies with all **local electrical codes, building regulations, fire safety standards, and utility requirements** before beginning installation.

This user manual provides general installation guidance; however, it does **not** replace any health, safety, electrical, structural, or building code requirements.

A complete on-site evaluation, including structural suitability, environmental risks, fire safety considerations, and cable routing planning - must be performed by qualified personnel prior to installation.

## 3.5 Step 5- Review Wall and Structural Requirements

### Warning

- **Indoor installations:**

A certified **fire separation barrier** must be provided between the battery installation area and other occupied spaces.

- **Outdoor installations:**

The battery must be installed at a safe distance from buildings, public pathways, and any exit routes, and must be protected from **direct rain and sunlight**.

- Always follow **local building codes and fire protection standards**, and ensure that all applicable fire-rating and clearance requirements are met.

### Fix The Position

The XESHES battery may be installed either indoors or outdoors.

To ensure optimal cooling performance and protection against environmental exposure, it is recommended to install the unit in a **well-ventilated, shaded area** that avoids direct sunlight, rain, and snow.

Proper placement helps extend the service life of the system and improves long-term reliability.

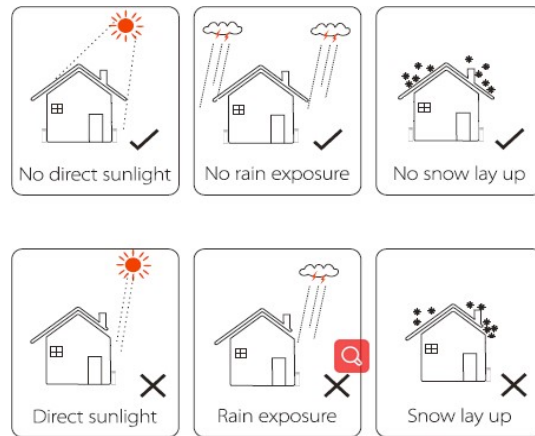

### Installation Angle

- The XESHES battery must be installed **vertically on the ground**, positioned close to the wall as designed.
- Do **not** place the battery on uneven, soft, unstable, or inclined surfaces.
- Ensure that the installation surface is **solid, level, and well-ventilated**.
- The enclosure must remain upright at all times. Tilting or laying the battery flat may result in internal damage or improper operation.

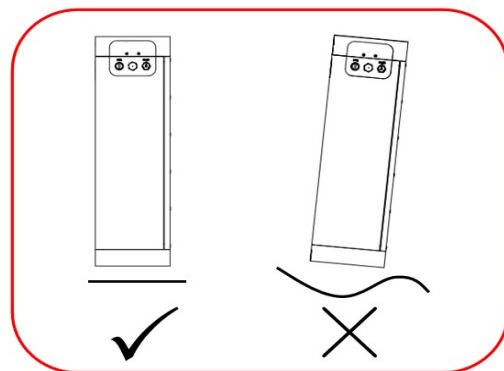

## 3.6 Step 6- Select an Appropriate Installation Location

### Ground and Structural Requirements

- Ensure that the ground surface has a **load-bearing capacity of at least 200 kPa** to safely support the battery.
- The installation area must **not** be accessible to children and must be free from explosive, flammable, or corrosive environments.

## General Placement Requirements

- For residential project installations, choose a **safe, ventilated, and weather-protected** location to avoid exposure to direct sunlight, rain, and snow.
- The XESHES energy storage battery must be installed **vertically on the ground**. Installing the unit horizontally may cause internal damage.
- Maintain **at least 100 mm** of clearance around the enclosure for proper airflow.
- Do not install the battery near heat sources or walls exposed to direct sunlight (e.g., boiler room walls) unless adequate insulation is provided.

## Temperature and Heating Film Considerations

To ensure optimal performance and system protection, install the battery **within its specified operating temperature range**. If the temperature exceeds the allowable range, the battery may automatically shut down to prevent damage.

### Heating Film Models (XESHES-U-48V13.5kWh-A-H)

- **Activation Threshold:** The heating film activates when cell temperature drops below **+5°C** and stops when cell temperature rises above **+10°C**.
- **Energy Consumption:** Heating consumes stored battery energy and may temporarily reduce system efficiency.
- **Low-Temperature Performance:** At ambient temperatures of **-18°C or above**, the heating film can warm the cell to a rechargeable state. In extremely cold environments, additional **thermal insulation is recommended** to prevent operational failure.
- The heating film does **not** affect heat dissipation during high-temperature operation.
- In addition, a thermal insulation is recommended for battery when the temperatures fall below -18°C to prevent operational failure.

## Fire Separation and Safety Requirements

- For indoor installations, a **2-hour fire-rated barrier** must separate the battery room from other occupied areas. Alternatively, installation may be permitted in locations accessible to firefighting vehicles (e.g., underground garages), depending on local regulations.
- Follow all local fire codes and AHJ (Authority Having Jurisdiction) requirements.

## Minimum Clearance Requirements

- When installed near a wall, the battery must be **at least 1 meter** away from windows and doors.
- For outdoor installations:
  - 1) Maintain **≥ 10 cm** of clearance from exposed building surfaces, public roads, or other structures.
  - 2) Maintain **≥ 10 cm** of separation from exits and evacuation pathways.

## Flooding Prevention

- If installed in a low-lying area, elevate the battery on a raised platform to prevent flooding or water ingress.

## Installation and Wiring Considerations

- Install the battery **only when it is completely powered off**. Be cautious of residual heat from the radiator or internal components.
- Installation may only be performed by **qualified personnel**.
- To minimize resistance and power loss, keep cable lengths between the XESHES battery, PCS, and grid connection board **as short as possible**.
- Install the battery **close to the cable entry point** to ensure secure and efficient connection to the PCS.

## 3.7 Step 7- Plan Installation Spacing

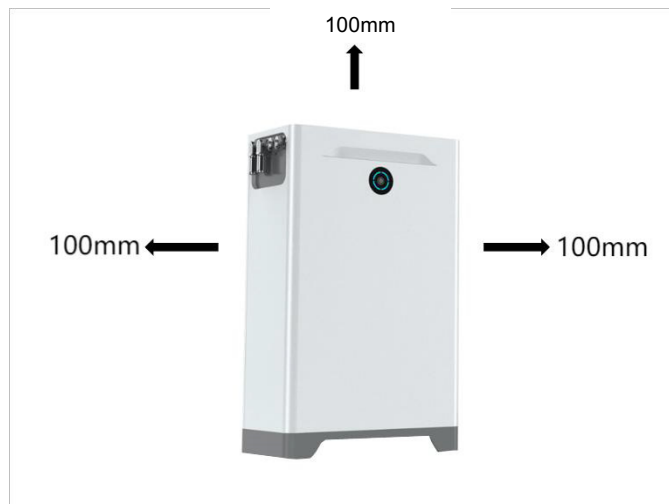

The spacing dimensions above are recommended values and may be adjusted based on the actual installation conditions. However, all adjustments must still comply with the requirements outlined in Step 6

## Chapter 4 Installation

## 4.1 Junction box system installation(optional)

### Step 1: Bracket Installation

Remove the mounting bracket from the junction box assembly. Use **two M5 hex flange nuts** to secure the bracket to the junction box body.

*Note:* One of the nuts must be assembled together with an **M5 claw-type grounding washer** to ensure proper grounding.

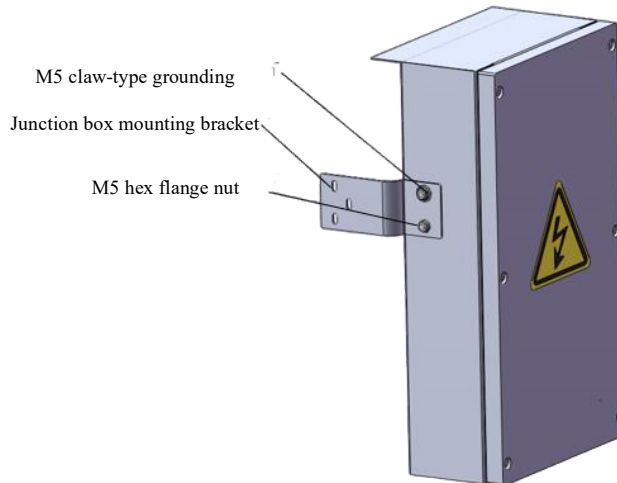

### Step 2: Preparation for Assembly

Locate the **M4 × 10 countersunk Phillips screw** on the power-cable side of the battery pack and remove it completely.

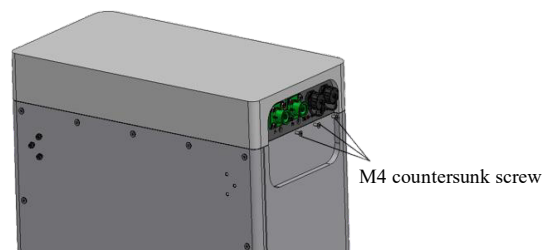

### Step 3: Junction Box Positioning

Remove the junction box cover plate.

Peel off the protective film from the **3M adhesive tape** on the rear side of the junction box.

Align the mounting holes of the junction box with the corresponding holes on the battery pack, and firmly attach it to the battery.



#### Step 4: Internal Fixation

Using **M4 × 12 cross-recessed hex truss-head three-combination bolts**, fasten the three internal mounting points of the junction box.

Insert the power cable harness into the power connector until a “**click**” is heard, indicating proper engagement.

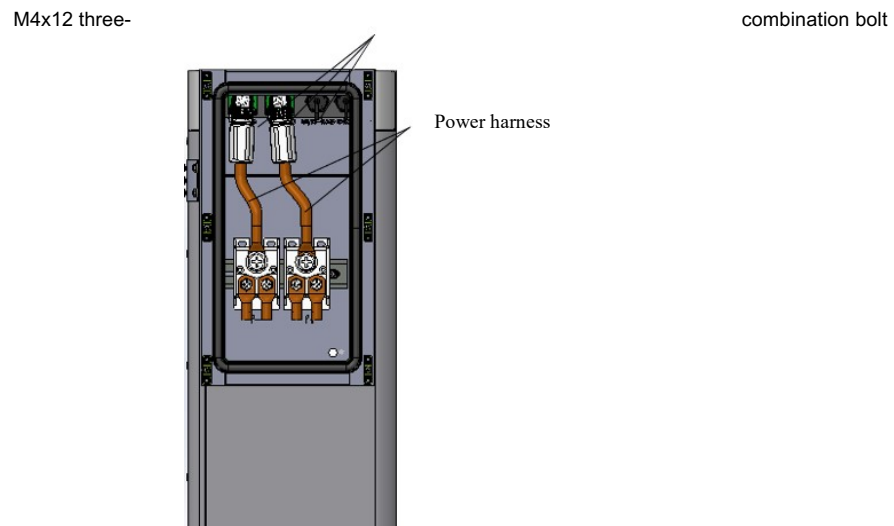

#### Step 5: External Fixation

Secure the three **M4 × 12 cross-recessed hex socket head combination bolts** at the bracket mounting positions.

*Note:* One of these bolts must include an **M4 claw-type grounding washer**. If a rear support bracket will be installed later, this bolt may be temporarily omitted.

Tighten the **M8 screw** at the one-to-two terminal using **15 Nm torque**.

Reinstall the junction box cover plate.

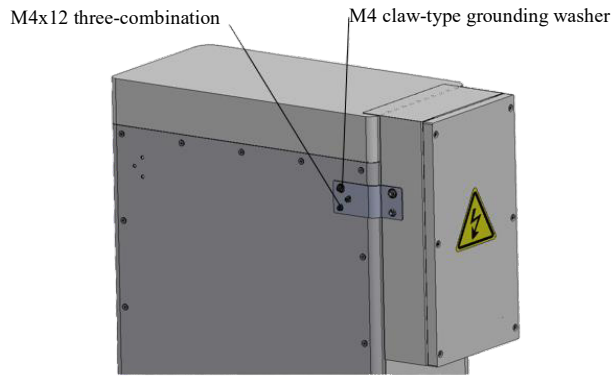

## 4.2 Rear Bracket Installation

### Step 1: Positioning and Installation

Align the three rear mounting brackets with the designated positions on the back of the battery pack.

Ensure each bracket fits snugly against the battery surface.

Secure each bracket using **M4 × 12 three-combination bolts**.

### Step 2: Special Installation for Bracket 2

Remove the pre-installed **M4 × 12 bolt** at the specified position.

Align bracket 2 with the mounting hole and re-secure it using an **M4 × 16 three-combination bolt**, ensuring proper mechanical engagement.

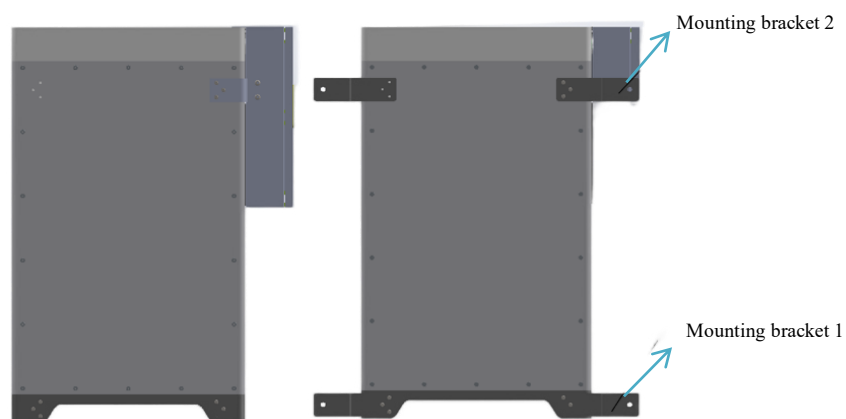

## 4.3 Product installation

### ⚠ Warning

- The XESHES energy storage battery is heavy ( $\approx 116$  kg). Always use **two or more trained personnel** or appropriate lifting tools when moving the unit.
- Follow the installation schematic strictly to avoid improper placement or structural instability.
- For multi-unit installations, repeat the full installation process for each battery before wiring them in parallel.

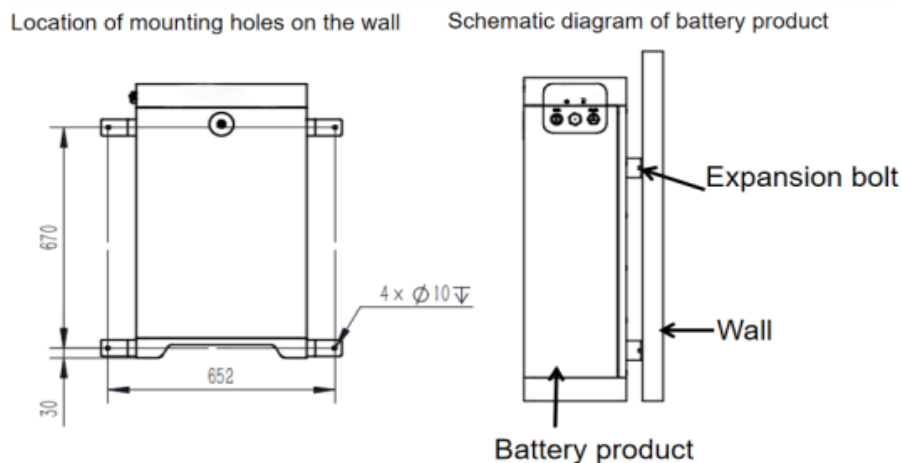

### Installation Steps

- 
- |        |  |
|--------|--|
| Step 1 | <b>Mark the installation height and drill positions using a ruler and level.</b>                               |
| Step 2 | Drill four $\varnothing 10 \times 70$ mm holes and install the expansion bolts securely.                       |
| Step 3 | Lift and move the battery into position, align it with the mounting brackets, and secure the battery in place. |
-

# Chapter 5. Wiring

## Warning

- Before and after wiring, use a multimeter to measure the DC voltage between the battery's positive and negative terminals.

The initial battery voltage must be **48–54 VDC**.

If the reading falls outside this range, contact your authorized Pion Power dealer.

- Keep DC cable length between the battery and PCS **as short as possible** to minimize voltage drop and power loss.

Parallel DC cables should be kept **equal or similar in length**.

- Ensure the **battery knob switch is turned OFF** before connecting any cables.



## Wiring Steps

|        |   |
|--------|---|
| Step 1 | <b>Confirm the battery pack knob switch is in the OFF position.</b>   |
| Step 2 | Connect the <b>positive and negative DC power terminals</b> to the corresponding PCS DC ports using appropriately rated cables. |
| Step 3 | Connect the <b>PCS communication cable</b> from the battery to the PCS communication interface.                                 |
| Step 4 | Connect the <b>parallel communication cable</b> from the master battery pack to the next battery in sequence (master → slave).  |
| Step 5 | Turn on the battery knob switch and verify that the <b>power indicator</b> illuminates.   |

## 5.1 Wiring diagram

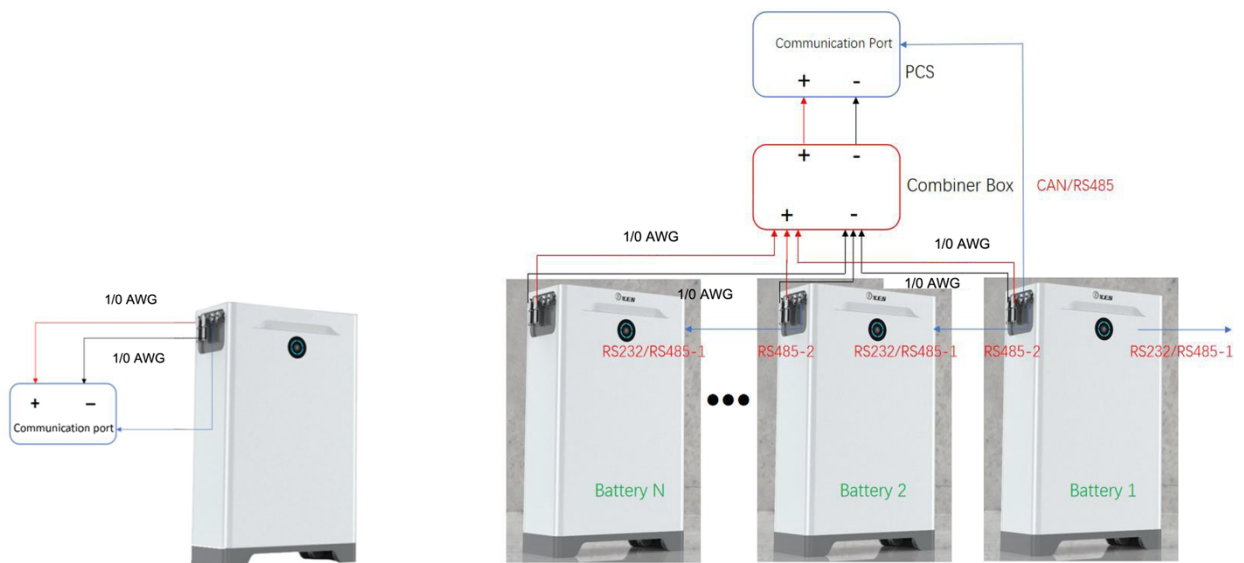

Stand-alone Wire Connection

Cable connection of multiple units

### ! Attention

- According to the design specification, a single battery pack is suitable only for PCS models rated for a **maximum of 100 A charging and 140 A discharging**.
- Cable dimensions provided in this manual are for reference only. All conductor sizes must comply with **local electrical codes and standards**.
- To prevent circulating current protection from being triggered, ensure that the **voltage difference between battery packs is less than 1 V** before connecting them in parallel.
- Always turn **OFF** the battery knob switch before connecting any power cables.
- **Reverse polarity is strictly prohibited**. Incorrect wiring may cause equipment damage or severe safety hazards.
- Connect all communication cables strictly according to the wiring schematic to avoid communication faults.
- After all power cables and communication harnesses are properly connected, turn on the battery knob switches **one unit at a time**, following the recommended sequence.

## 5.2 Wiring details

### A. Interface definition of the RS232 communication cable for the battery pack

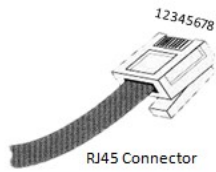

| RJ45     | 1  | 2  | 3   | 4 | 5 | 6 | 7 | 8 |
|----------|----|----|-----|---|---|---|---|---|
| BMS Port | RX | TX | GND | / | / | / | / | / |

### B. Interface definition of battery pack parallel communication cable

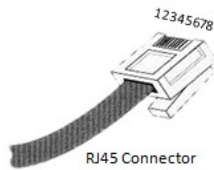

| RJ45     | 1 | 2 | 3 | 4 | 5     | 6   | 7       | 8       |
|----------|---|---|---|---|-------|-----|---------|---------|
| BMS Port | / | / | / | / | UP_IN | GND | RS485-A | RS485-B |

### C. Interface Definition for Communication between Battery Pack and RS485

#### Communication Inverter Communication Cable

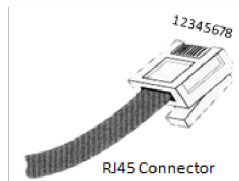

| RJ45     | 1       | 2       | 3   | 4 | 5 | 6 | 7 | 8 |
|----------|---------|---------|-----|---|---|---|---|---|
| BMS Port | RS485-B | RS485-A | GND | / | / | / | / | / |

### D. Interface Definition for Communication Cables between Battery Pack and CAN

#### Inverter

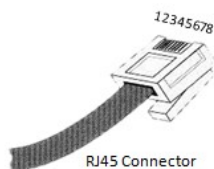

| RJ45     | 1 | 2 | 3 | 4     | 5     | 6 | 7 | 8 |
|----------|---|---|---|-------|-------|---|---|---|
| BMS Port | / | / | / | CAN_H | CAN_L | / | / | / |

## E. Battery pack communication cable wiring

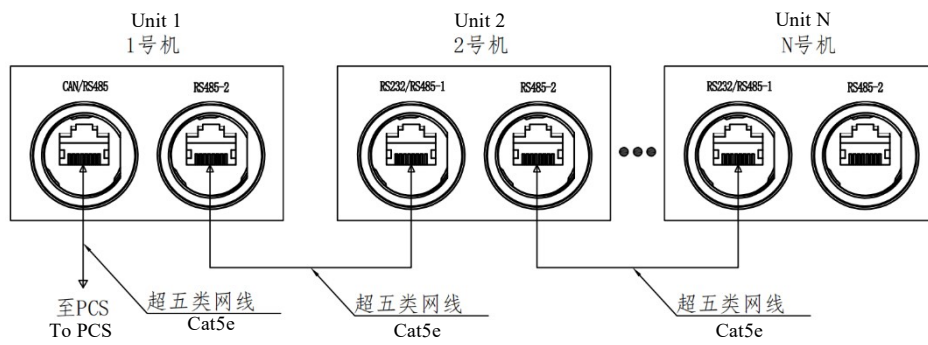

Follow the wiring diagram above when connecting the parallel communication cables between battery packs. After all wiring is completed, turn on the battery knob switches **in reverse order**, starting from the last unit (**Unit N**) and ending with the first unit (**Unit 1**).

Unit 1 will automatically function as the **master battery** and initiate the addressing process.

If addressing fails, all indicator lights on the affected battery will begin flashing simultaneously to signal the error.

# Chapter 6 Commissioning, Operation and Maintenance

## 6.1 Commissioning Steps

---

|        |  |
|--------|--|
| Step 1 | Turn on the battery knob switch and wait until the SOC indicator illuminates steadily, confirming that all XESHES batteries are powered on.                                    |
| Step 2 | Power on the PCS and access the <b>Unit Configuration</b> interface.   |
| Step 3 | In the configuration menu, select “ <b>Pion Power XESHES Energy Storage Product.</b> ”   |
| Step 4 | Choose the desired PCS operating mode (e.g., peak load shifting, backup power mode, or self-generation and self-consumption).  |
| Step 5 | Verify that communication between the PCS and the XESHES battery is successfully established.  |
| Step 6 | If communication fails, an error message will appear on the PCS display. Refer to the <b>Troubleshooting</b> section for corrective actions.                                   |
| Step 7 | If the issue cannot be resolved after following the troubleshooting steps, contact the authorized after-sales service provider for the XESHES battery or the PCS manufacturer. |

---

## 6.2 Operation

When using XESHES products, always follow the instructions in this manual to ensure proper operation and maintenance. The system supports three operating modes:

1. **Normal Mode**
2. **Standby / Sleep Mode**
3. **Storage / Transportation Mode**

### Notice

- Ensure that **all XESHES energy storage batteries in the system are set to the same operating mode**. Mixed modes may cause improper operation or communication errors.
- To protect battery life and maintain optimal performance, it is recommended to keep the **PV system, PCS, and XESHES battery operating regularly**. Extended periods of system inactivity should be avoided whenever possible.

| Mode   | Step   | Function          | Description   |
|--|--------|-------------------|---|
| <b>Normal Mode</b> (service condition: normal operation)                                 | Step 1 | Power On          | Turn on the XESHES battery knob switch until the SOC indicator is on.   |
|  | Step 2 | Power Off         | When XESHES battery is in standby state, turn off the knob switch until the SOC indicator turns off.  |
| <b>Standby &amp; Sleep Mode</b>  | Step 3 | Automatic Standby | If XESHES battery fails to connect with PCS communication in more than 5 minutes, it will automatically enter Standby Mode to conserve power.   |
|  | Step 4 | Sleep             | Press and hold the reset button of XESHES battery for <b>3-6 seconds</b> , and release the reset button until the SOC indicator turns off, or when the battery remains in standby for more than 24 hours. |
|  | Step 5 | Wake Up           | Press and hold the reset button of XESHES battery for <b>3-6 seconds</b> and release the reset button until the SOC indicator turns on.   |
| <b>Storage/Transportation Mode</b> (service condition: during storage or transportation) | Step 6 | Forced Shutdown   | When XESHES battery is in standby state, turn off the knob switch until the SOC indicator turns off.  |
|  | Step 7 | Wake Up           | Turn on the XESHES battery knob switch until the SOC indicator is on.   |

## 6.3 Cleaning

To maintain optimal airflow and system performance, keep the top and surrounding area of the XESHES energy storage battery free from leaves, dust, and other debris.

Clean the exterior surface using a **soft, lint-free cloth**.

If necessary, lightly dampen the cloth with clean water.

To prevent damage:

- Do **not** use high-pressure water, hoses, or spray cleaners.
- Do **not** use detergents, solvents, or chemical cleaning agents of any kind.

Proper cleaning helps ensure adequate natural convection and extends the lifespan of the battery system.

## 6.4 Maintenance

Maintenance and repair of the XESHES energy storage battery must be performed **only by certified installers** trained by Pion Power Electric Storage.

If any abnormal conditions occur, refer to **Section 7.1 — Troubleshooting** and contact your authorized Pion Power dealer for assistance.

For long-term storage:

- Charge the battery to **above 75%** before shutting it down for storage.
- Recharge the battery **every three months** during storage to prevent over-discharge.
- During regular use, recharge the battery promptly whenever its state of charge falls below **10%** to help maintain long-term health and performance.

# Chapter 7: Appendix

## 7.1 Troubleshooting

If the XESHES battery is not operating normally, follow the steps below to identify and correct common issues.

If the problem persists after performing the recommended actions, please contact your authorized Pion Power dealer.

| Problem  | Solution  |
|--|---|
| The product fails to operate   | Check the ambient indoor temperature and improve ventilation if necessary. Ensure conditions are within the specified operating range.  |
| Neither the PCS nor the XESHES battery responds                          | Turn off the PCS circuit breaker and wait at least <b>one minute</b> before turning it back on. This resets the PCS and may restore communication.  |
| Power failure or outage occurs while the standby power mode is operating | Reduce the connected load and check the circuit breaker for tripping. Restore power if required.  |
| Unable to communicate with the PCS through its portal                    | <ol style="list-style-type: none"><li>Ensure the RJ45 connector is fully inserted into the communication port.</li><li>Verify that the RJ45 pin configuration follows the <b>T568B standard</b>.</li><li>Check that the network cable is correctly crimped and not damaged.</li></ol> |

## 7.2 Emergency

### Water Damage

If the XESHES battery becomes submerged in water or is exposed to severe moisture:

- 1) **Do not touch or attempt to move the battery.**
- 2) Keep all individuals and animals away from the area.
- 3) Immediately contact your authorized Pion Power dealer for technical support and further instructions.

Water-damaged high-voltage equipment poses a significant electrical hazard.

## Physical Damage

The XESHES battery is designed with multiple safety layers and features high structural integrity. However, under extreme external impact, the battery may be damaged and could emit smoke.

If smoke is observed:

- 1) **Stay away from the battery** and allow the smoke to dissipate naturally.
- 2) Once conditions are safe, turn off the battery power.
- 3) Do not attempt to use or repair the damaged unit.
- 4) Return the product to the authorized dealer for inspection.

Damaged batteries can pose serious risks to personal safety and property. Only trained professionals should handle transportation or evaluation of the unit.

If the battery is visibly damaged:

- 1) Package it securely in its **original container** (if available).
- 2) Return it to the authorized dealer for proper disposal or replacement.

## Continuous Smoke Emission

If the battery emits continuous smoke or signs of thermal activity, ensure that the following emergency equipment is nearby and accessible:

- 1) **SCBA** (Self-Contained Breathing Apparatus)
- 2) Protective equipment complying with **PPE Directive 89/686/EEC**
- 3) Fire extinguishers rated for electrical and lithium-battery fires, including:
  - **Novec 1230**
  - **FM-200**
  - **CO<sub>2</sub> extinguishers**

**Do not use water** to extinguish a battery fire.

## 7.3 Specification Datasheet

| Model                                       | XESHES-U-48V 13.5kWh-A   | XESHES-U-48V 13.5kWh-A-H   |
|---|--|--|
| Rated battery power                         | 13.44kWh   | 13.44kWh   |
| Rated capacity                              | 280Ah  | 280Ah  |
| Depth of discharge                          | 90% DOD  | 90% DOD  |
| Rated battery voltage                       | 48VDC  | 48VDC  |
| Voltage range                               | 40.5~53.25VDC  | 40.5~53.25VDC  |
| Maximum charge voltage                      | 53.25VDC   | 53.25VDC   |
| Rated discharge current                     | 140A   | 140A   |
| Rated charge current                        | 100A   | 100A   |
| Maximum discharge current                   | 140A   | 140A   |
| Maximum charge current                      | 100A   | 100A   |
| Efficiency                                  | >93%   | >93%   |
| Environmental conditions                    | Outdoor  | Outdoor  |
| Operating temperature                       | Charging: 0°C~40°C   | Charging: -18°C~40°C   |
| Operating temperature                       | Discharging: -10°C~40°C  | Discharging: -10°C~40°C  |
| Dimensions (L * W * H)                      | 490±2*251.3±2*832±2mm  | 490±2*251.3±2*832±2mm  |
| Weight                                      | 116±5kg  | 116±5kg  |
| Cooling method                              | Natural cooling  | Natural cooling  |
| Case material                               | Metal  | Metal  |
| Installation method                         | Floor fixing   | Floor fixing   |
| Enclosure                                   | IP65   | IP65   |
| Service life                                | >10 years (1 charge cycle/day)   | >10 years (1 charge cycle/day)   |
| Communication mode                          | RS-232, RS-485, CAN  | RS-232, RS-485, CAN  |
| Protections                                 | Overvoltage, overcurrent, overtemperature, undervoltage, short circuit | Overvoltage, overcurrent, overtemperature, undervoltage, short circuit |
| Junction box system(Optional Configuration) | Dimensions (L * W * H):212±2*130±2*410±2mm<br>Weight: 6±1kg            | Dimensions (L * W * H):212±2*130±2*410±2mm<br>Weight: 6±1kg            |
| Heating function                            | Not Available  | Built-in Heating Film  |

## 7.4 Product Warranty

Warranty claims can only be accepted if they are submitted **within the applicable warranty period**. In addition, all warranty claims must be filed **within 30 days** from the date the product defect is first identified.

### Submitting a Warranty Claim

If the customer makes a reasonable warranty claim within the scope of the limited warranty:

- 1) The customer must immediately send a written notice to Pion Power, either by registered mail or by email to Pion Power's official service address.
- 2) The customer must also inform the original supplier or distributor from whom the product was purchased.

The notice must include:

- 1) The customer's name and address (and the dealer or installer information, if applicable).
- 2) Evidence demonstrating the product's defective performance.
- 3) Any additional documents, data, or information requested by Pion Power or its authorized agent to evaluate the claim.

### Review and Inspection Process

Pion Power or its authorized agent will review the submitted documents and may request that the customer send the defective product to a designated facility for further inspection.

After all evidence and product samples (if required) have been examined and verified:

#### **If the product is confirmed defective:**

The customer must provide the **original purchase invoice** before Pion Power or its authorized agent performs any warranty obligations under the limited warranty.

#### **If the product is found to meet the applicable warranty performance criteria:**

The customer shall reimburse Pion Power and/or its authorized agent for any costs incurred during testing, inspection, or verification.

#### **Warranty Claims Will Not Be Accepted If:**

- 1) The product's type label or serial number has been altered, removed, or rendered illegible.
- 2) The customer fails to provide the following original documents upon request:

- The complete set of invoices issued by the supplier for the purchase of the product;
  - The quality certificate issued by Pion Power;
  - Any additional evidence, documentation, or data required by Pion Power to evaluate the product's actual performance.
- 3) The warranty claim is not submitted to Pion Power **within 10 days** after the applicable warranty period expires.